

JOB No.		8598		BILL OF MATERIAL			SHEET 206	
Qty.	Unit	PC.	Minor	DESCRIPTION	LENGTH	STEEL	REMARKS	
1	1	206A		HSS5X5X3/8	15'-7 7/8"	A500-GR.B		
1	1		b206	FL1"X12"	1'-0"	A36		
2	2		c206	FL3/8"X3 1/2"	1'-0"	A36		
2	2		e206	FL3/8"X3 1/2"	9"	A36		
1	1		g206	FL3/8"X5"	5"	A36		
1	1	206B		HSS5X5X3/8	13'-11"	A500-GR.B		
1	1		b206	FL1"X12"	1'-0"	A36		
3	3		c206	FL3/8"X3 1/2"	1'-0"	A36		
1	1		g206	FL3/8"X5"	5"	A36		

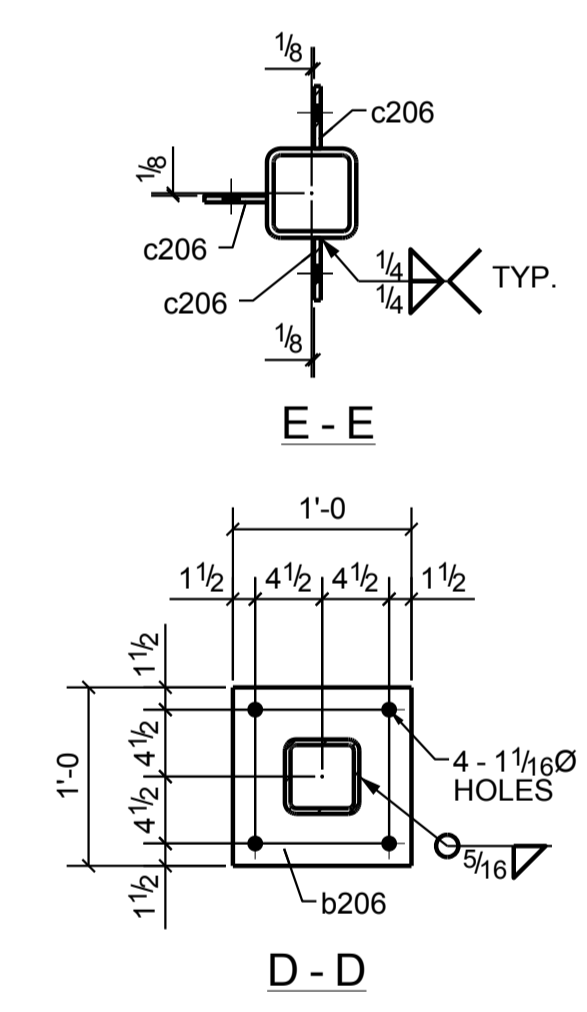
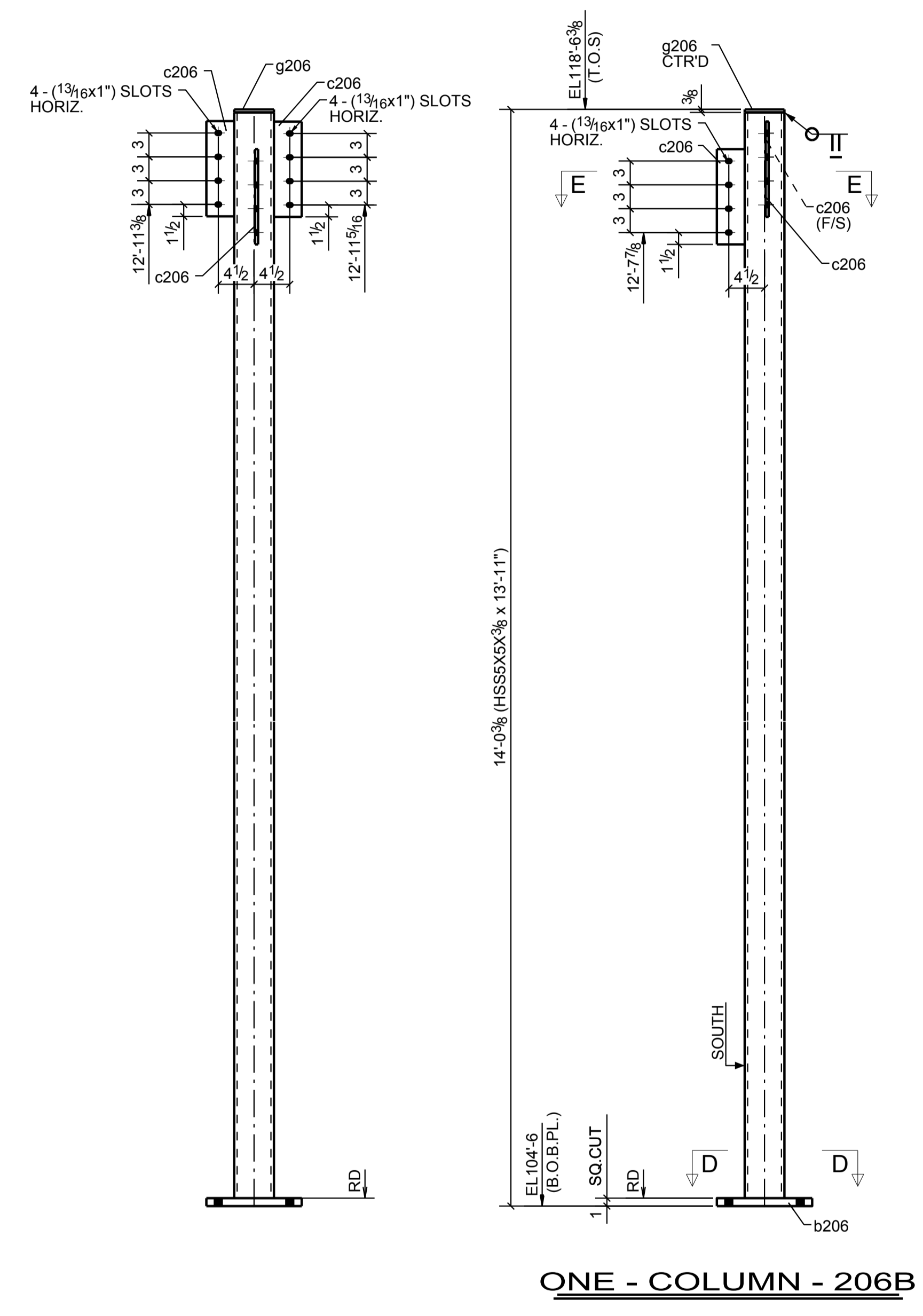
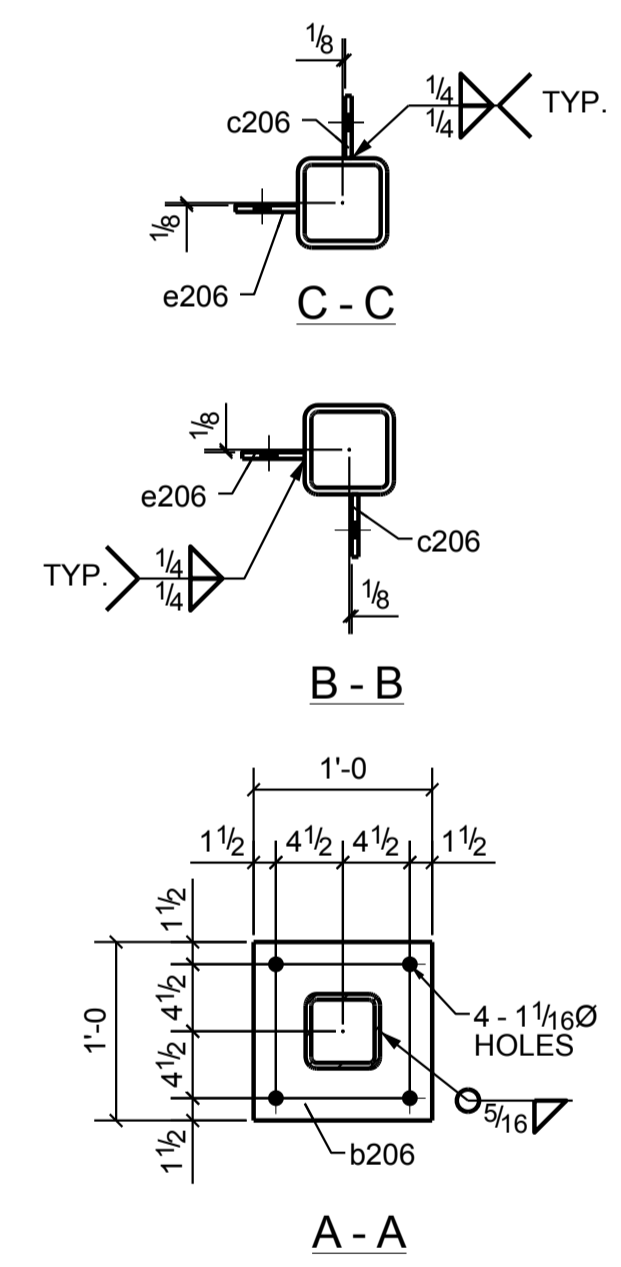
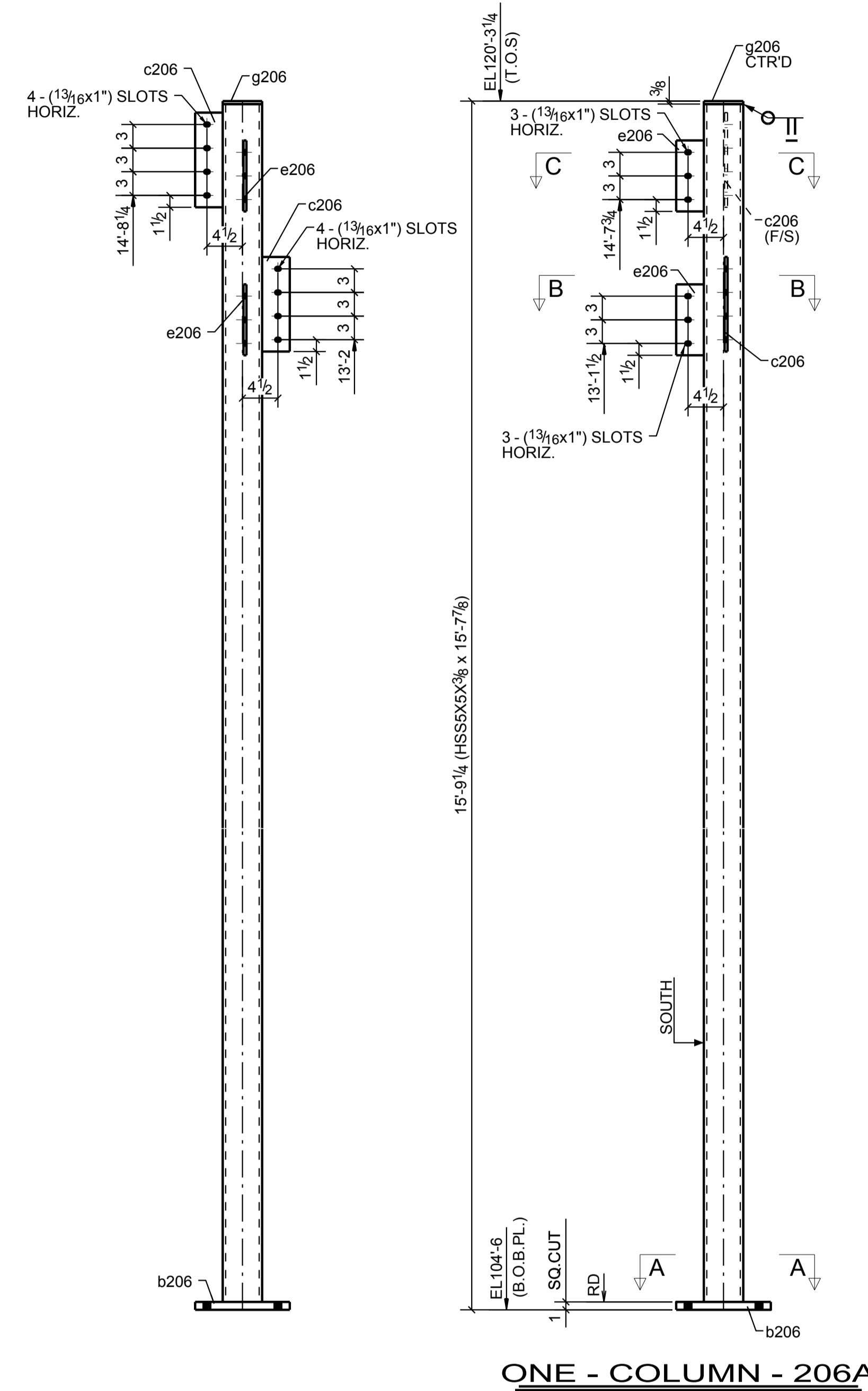

ASSM. MK.	TOTAL QTY	UNIT QTY	FIELD BOLTS	LENGTH	REMARKS

SAMPLE DRAWING