

BILL OF MATERIAL

Qty.	Unit	Description	Piece Mark	Length	Minor Mark	Steel Grade	Unit Wt.	Total Wt.	Remarks
1	1	C12X20.7	41ST1	20'-11 5/16"		A36	437.8	437.8	
38	38	L2X2X1/4		0'-10"	a14	A36	2.7	101.1	
1	1	L2X2X1/4		3'-0 3/8"	a17	A36	9.7	9.7	
2	2	L4X4X5/16		0'-4"	a18	A36	2.7	5.5	
1	1	L2X2X1/4		2'-11 5/8"	a19	A36	9.5	9.5	
1	1	C12X20.7		3'-8 3/8"	c6	A36	73.7	73.7	
1	1	C12X20.7		3'-10 5/16"	c7	A36	77.0	77.0	
1	1	C12X20.7		20'-9 3/8"	c9	A36	427.8	427.8	
1	1	C4X5.4		3'-3 3/4"	c18	A36	17.9	17.9	
19	19	10GA		1'-4 3/4"	m15	A36	23.6	448.5	
1	1	10GA		0'-6 3/8"	m43	A36	9.0	9.0	
1	1	FL3/8"X3 1/2"		0'-9"	p41	A36	3.4	3.4	
2	2	FL1/4"X3"		0'-6 3/4"	p64	A36	1.4	2.9	
19	19	PL1/8"X5 5/16"		3'-3 3/4"	p81	A36	7.4	141.1	
1	1	PL1/8"X3 15/16"		3'-3 3/4"	p103	A36	5.5	5.5	

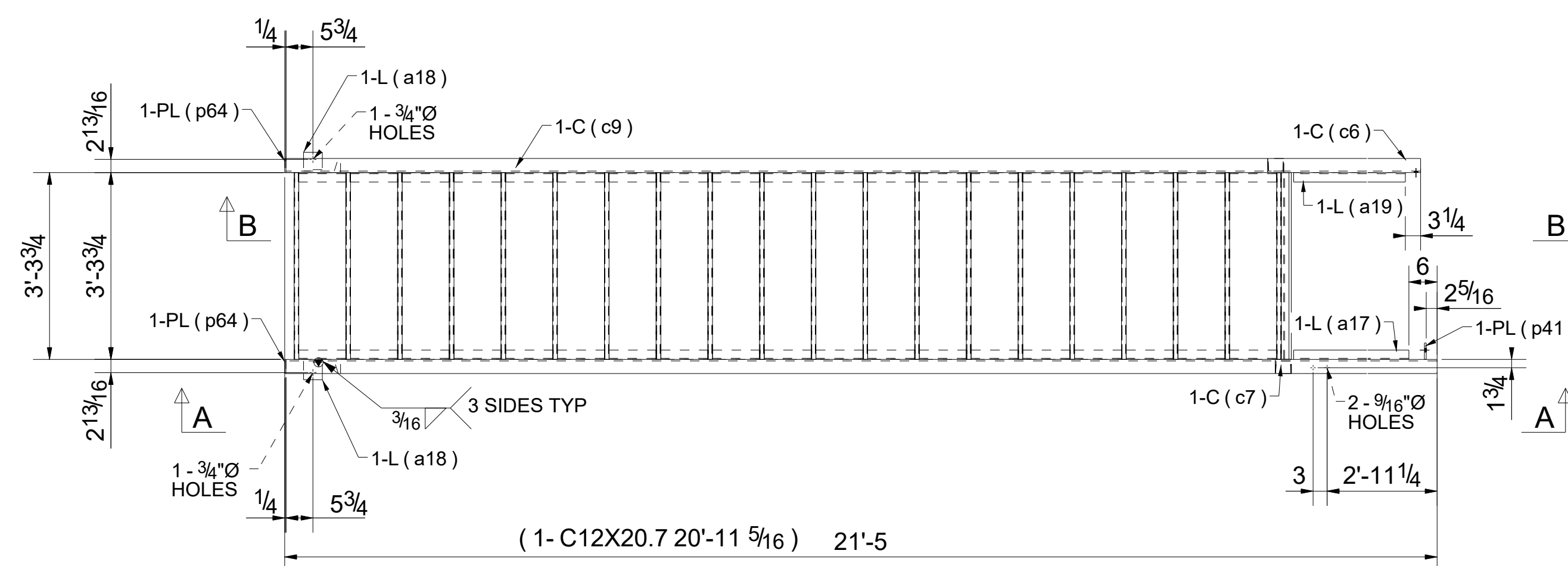
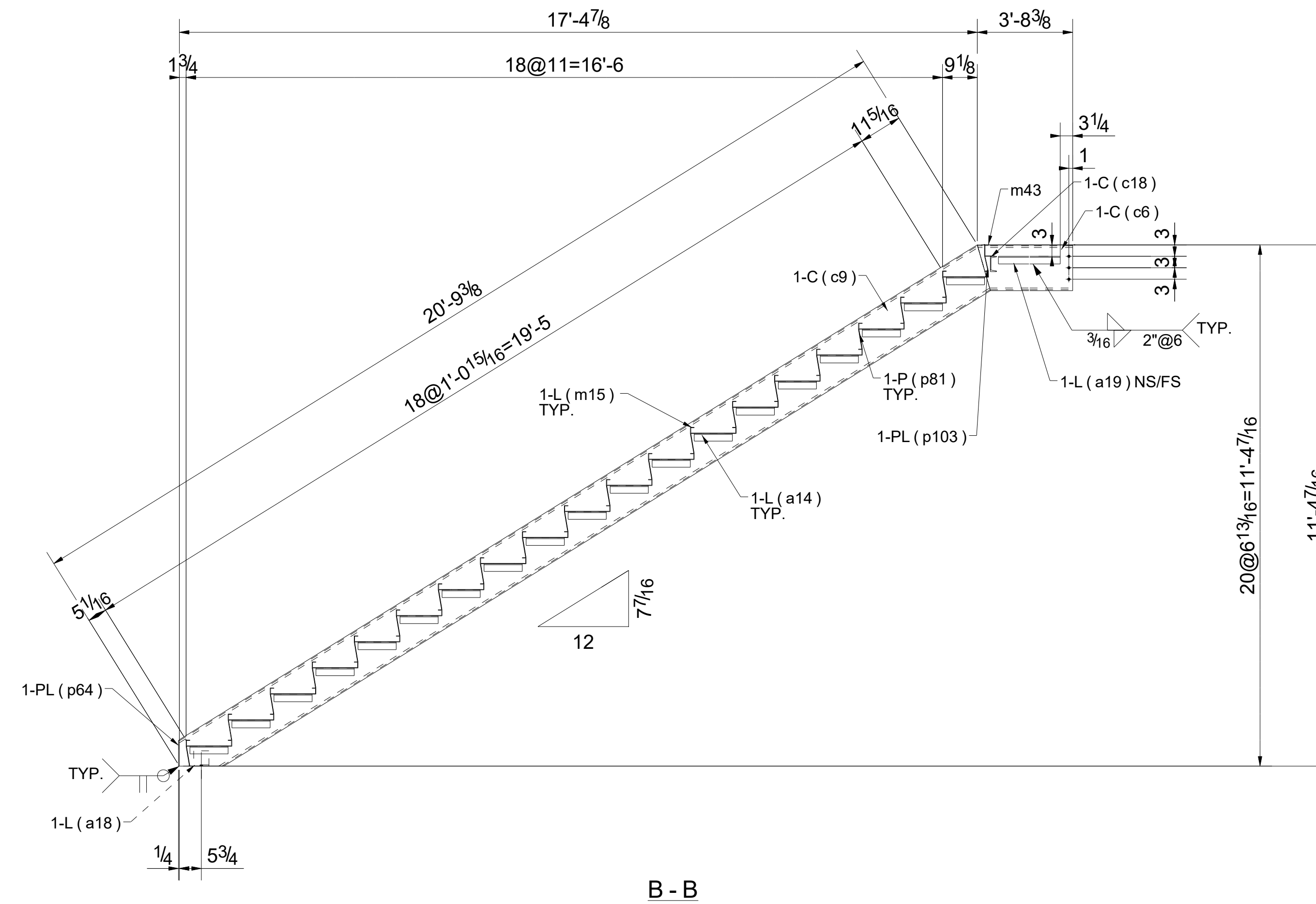
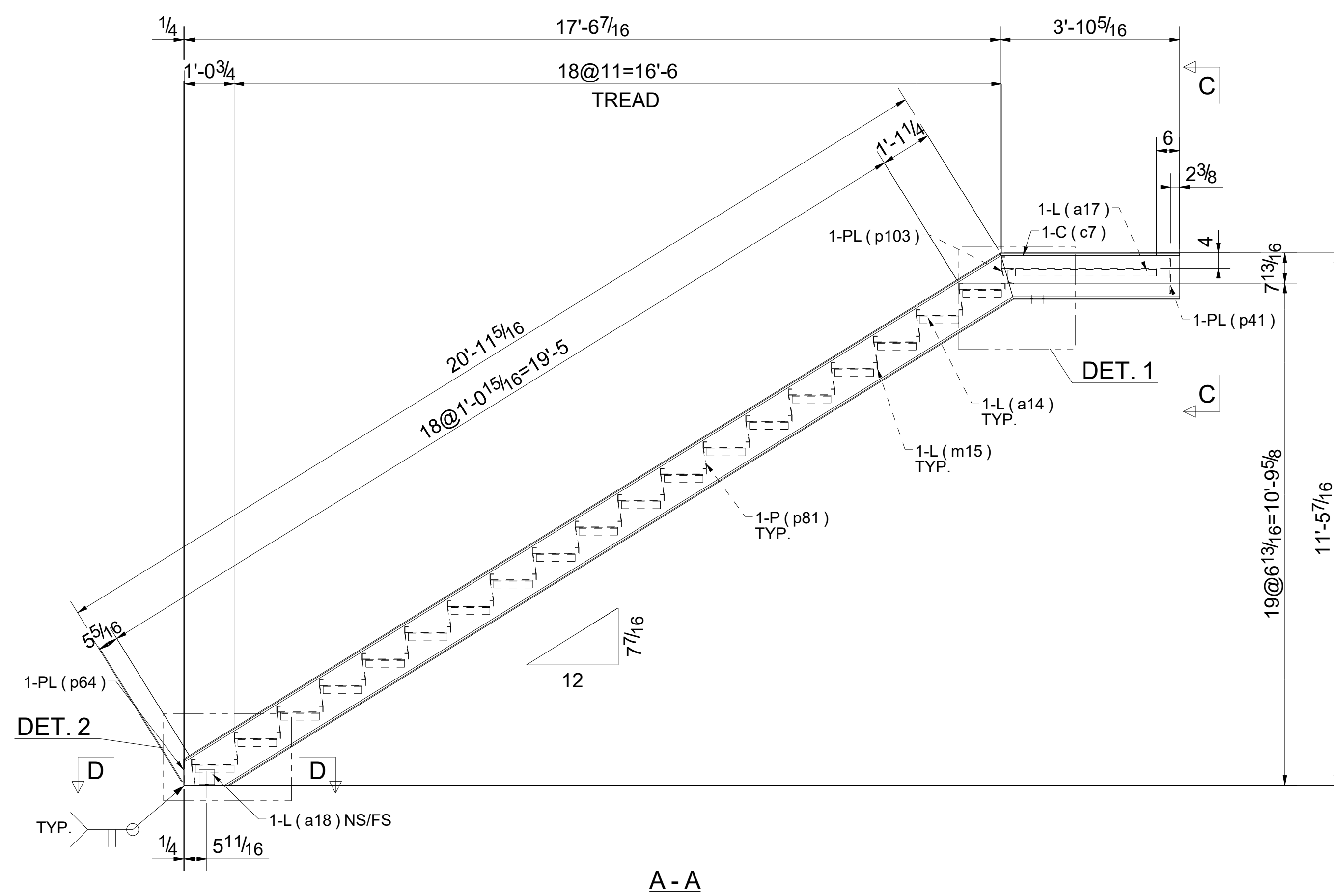
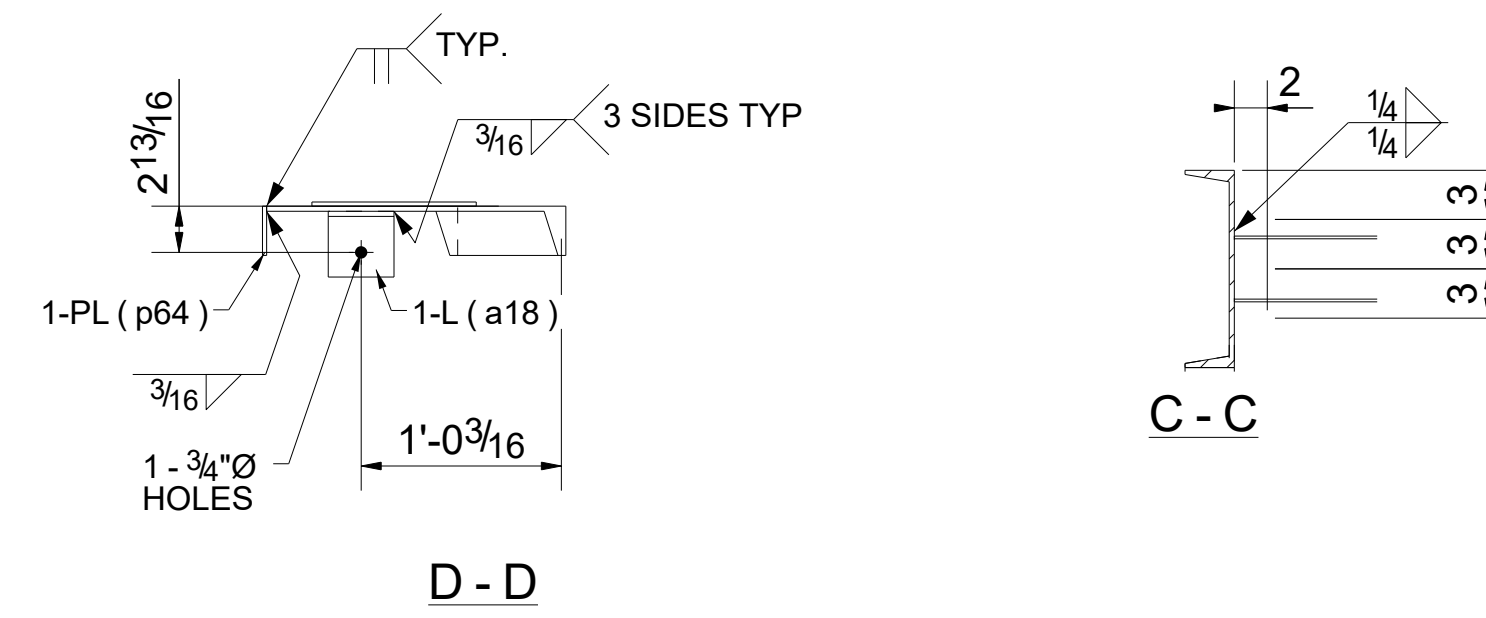
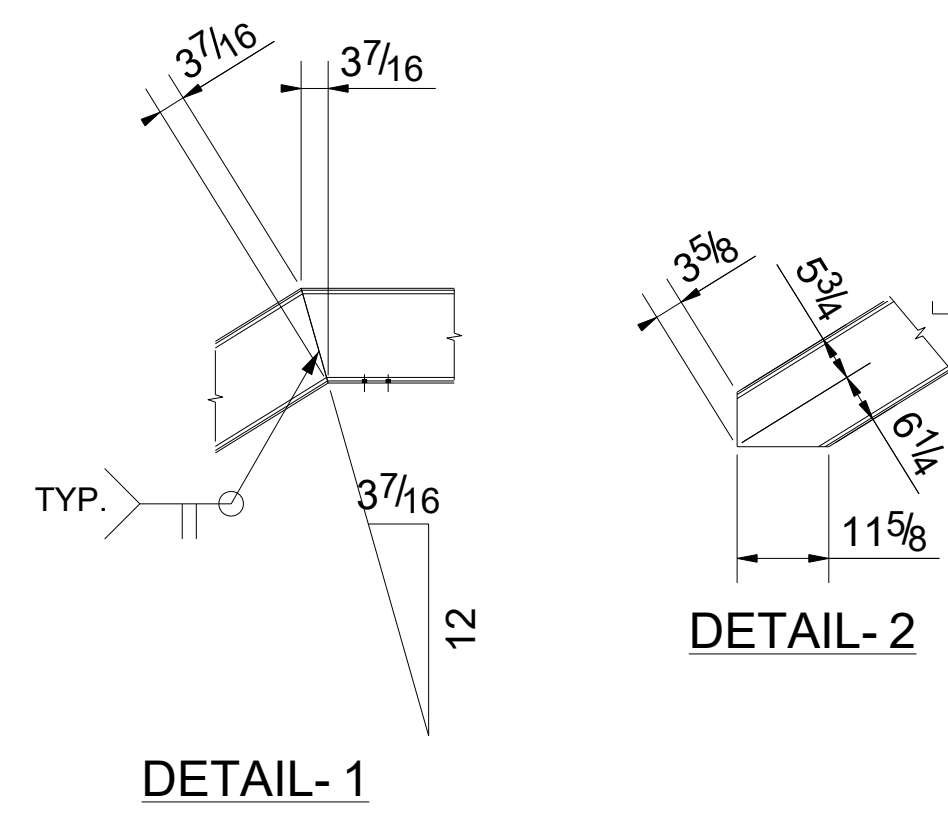

ONE - STRINGER - 41ST1