

BILL OF MATERIAL

Qty.	Unit	Description	Piece Mark	Length	Minor Mark	Steel Grade	Unit Wt.	Total Wt.	Remarks
1	1	C12X20.7	42ST1	8'-10 15/16"		A36	185.1	185.1	
14	14	L2X2X1/4		0'-10"	a14	A36	2.7	37.3	
1	1	L2X2X1/4		2'-9"	a20	A36	8.8	8.8	
1	1	C12X20.7		2'-10 5/8"	c1	A36	56.9	56.9	
1	1	C12X20.7		1'-2 7/16"	c2	A36	21.9	21.9	
1	1	C12X20.7		1'-2 7/16"	c3	A36	21.9	21.9	
1	1	C12X20.7		8'-1 7/16"	c4	A36	165.4	165.4	
1	1	C12X20.7		0'-8 7/16"	c10	A36	8.2	8.2	
2	2	C4X5.4		3'-3 1/4"	c20	A36	17.7	35.4	
1	1	10_GA		1'-2 7/8"	m12	A36	20.7	20.7	
7	7	10_GA		1'-4 3/4"	m107	A36	23.3	163.1	
1	1	FL1/4"X3"		0'-6"	p69	A36	1.3	1.3	
7	7	PL1/8"X5 5/16"		3'-3 1/4"	p87	A36	7.3	51.3	
1	1	FL3/8"X3"		0'-9"	p102	A36	2.9	2.9	
1	1	PL1/8"X5 3/16"		3'-3 1/4"	p108	A36	7.2	7.2	

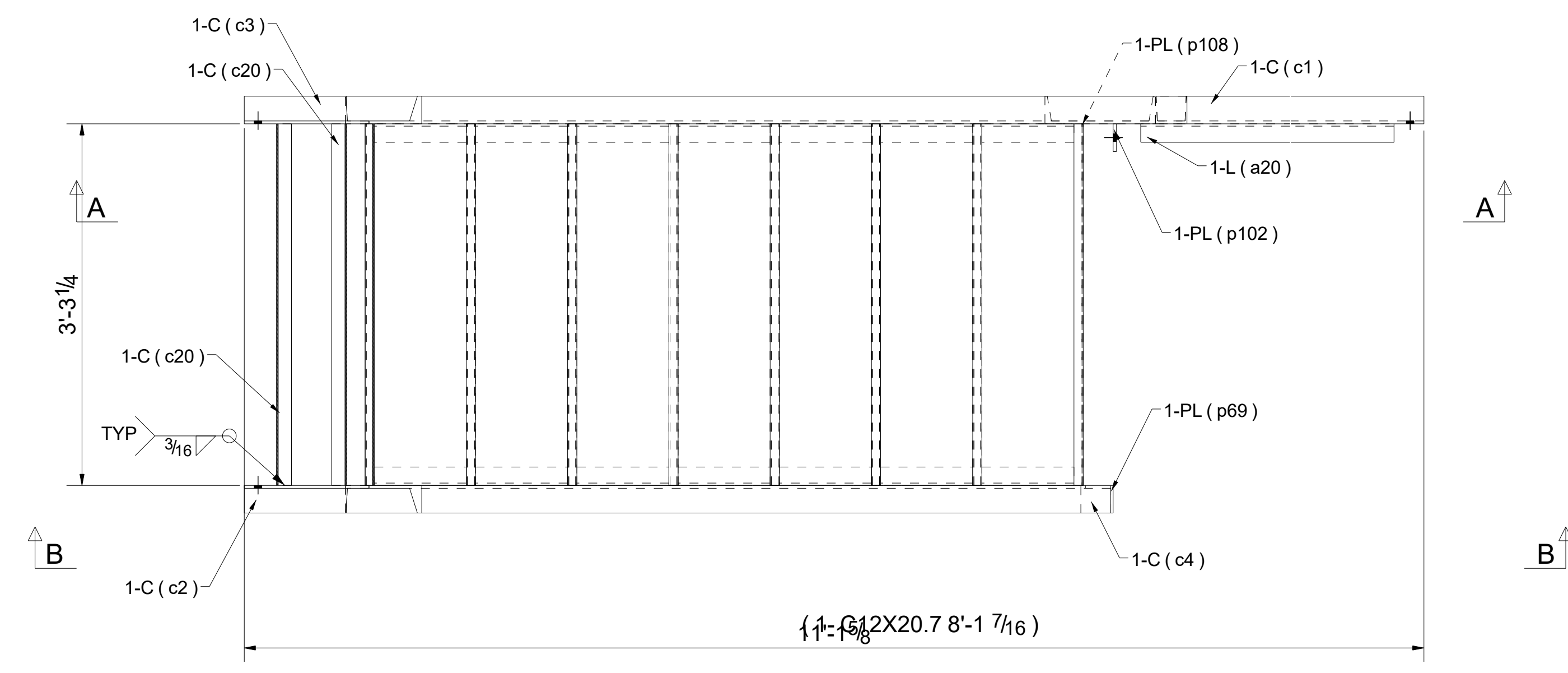
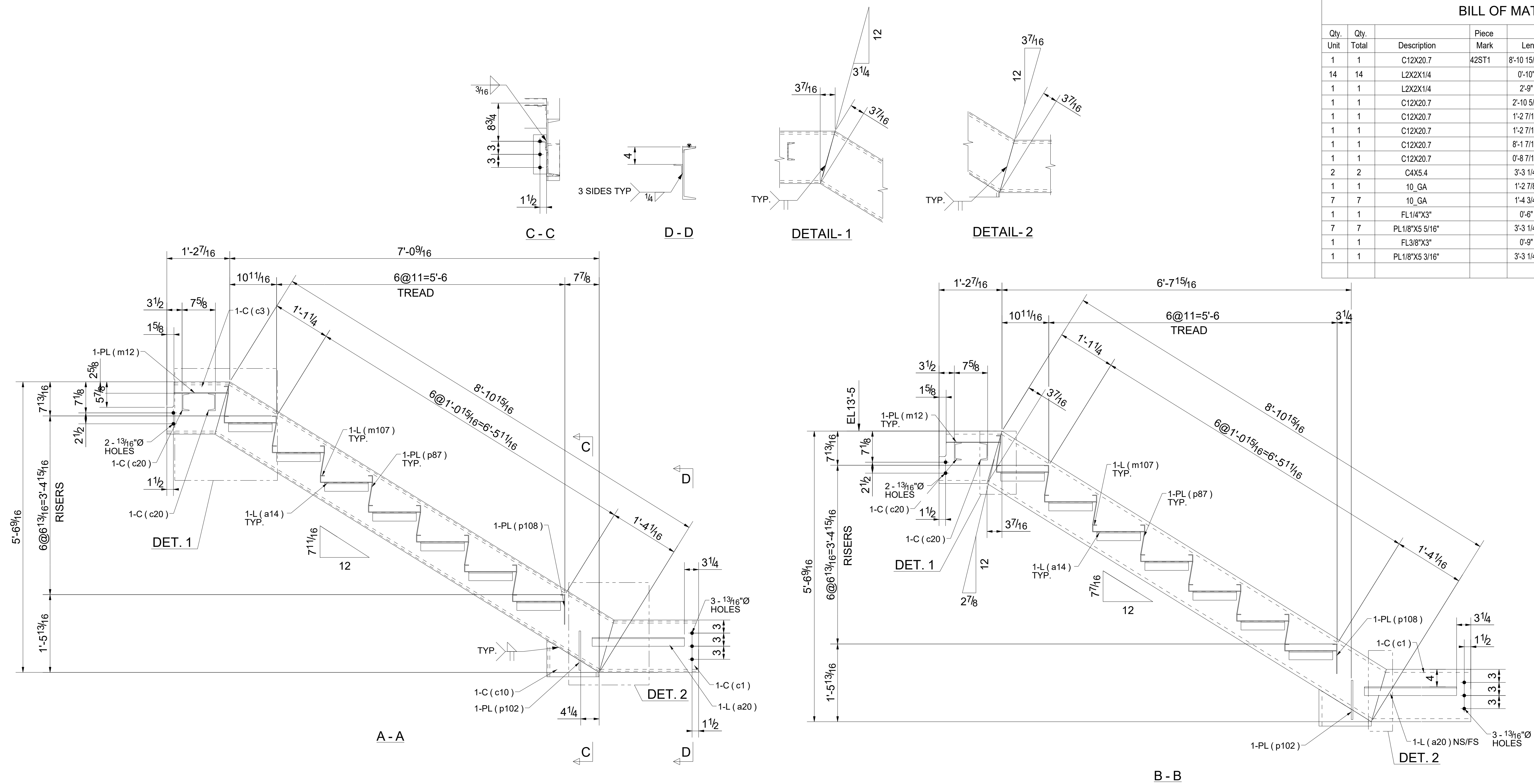

ONE - STRINGER - 42ST1